

WATER BIKE®

Installation and Users Guide

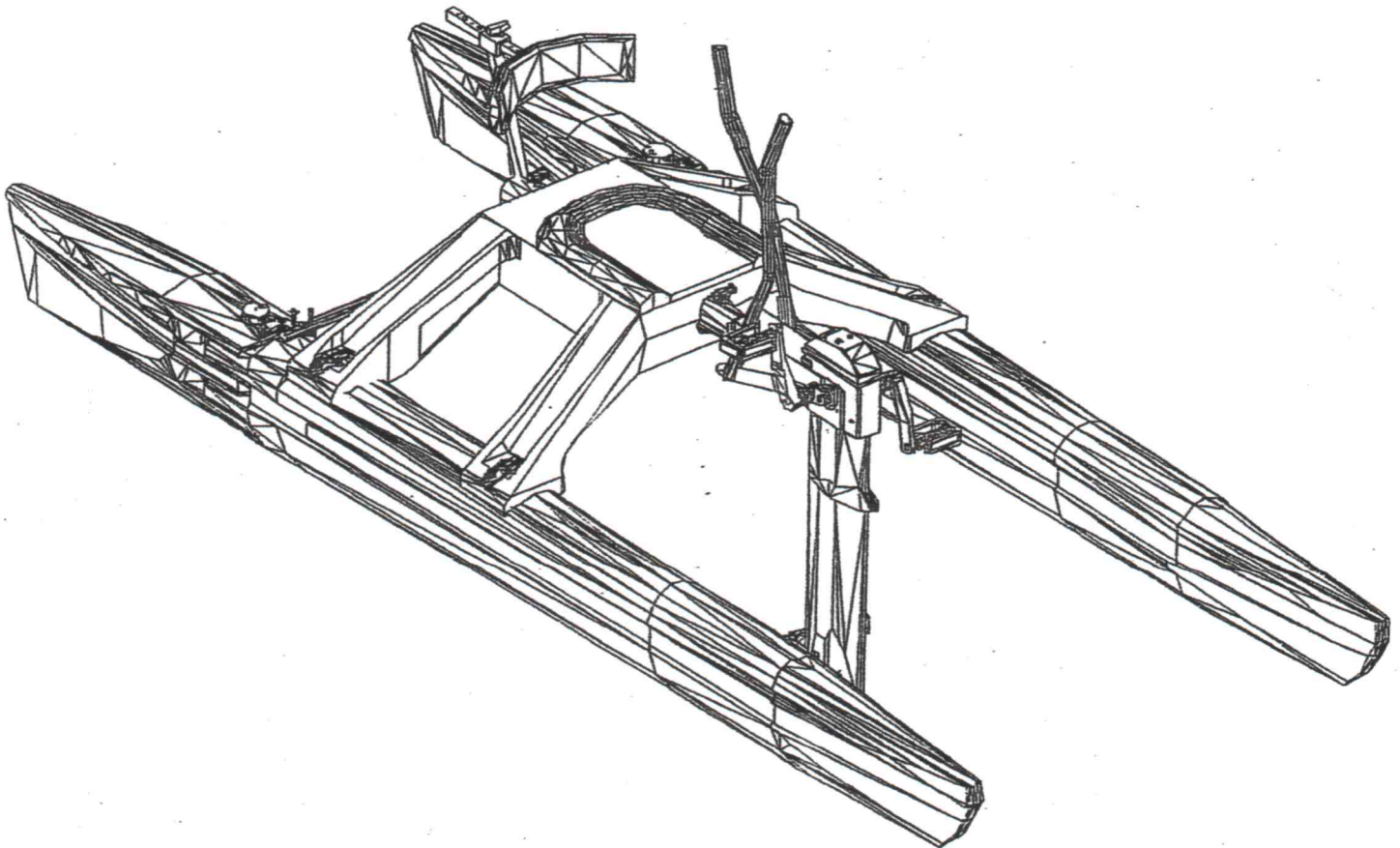

A Product of Meyers Boat Company
343 Lawrence St.
Adrian MI 49221

CastleCraft

website - www.castlecraft.com
PO # 3, Braidwood, IL 60408
815-458-6216 Telephone
888-274-8490 Toll Free

Voice (517)265-9821
Fax (517)263-2810

INTRODUCTION

Congratulations on your purchase of a waterbike! This human powered watercraft is a high-tech, yet simple design that lets you enjoy being on the water without relying on a motor or the wind. Your Waterbike offers excellent recreational opportunities while also providing you with exercise opportunities.

Please take the time to read this owner's manual carefully before assembly of your Waterbike. It contains important safety, assembly, operation, and maintenance information you will need to get the most from your Waterbike. All in all you will find your Waterbike a fun, safe and environmentally friendly way to enjoy the water. *Enjoy your Waterbike and remember to always think and be safe!*

If you need additional information call 1-800-WATERBIKE.

WATER BIKE® USER'S GUIDE

CONSUMER AND COMMERCIAL MODELS

The WATER BIKE® User's Guide covers the information you'll need to know about transporting, assembling, and using the WATER BIKE, as well as tips on safety and maintenance. Please take time to read the user's guide carefully before you ride your WATER BIKE. Most importantly remember to add the oil to the drive units and **CHECK THE CHAIN TENSION REGULARLY.**

Please be sure to complete and return the enclosed warranty registration card to validate your warranty.

ENJOYING THE WATER BIKE

The WATER BIKE is designed for both fitness and recreation. You can enjoy riding it for an aerobic workout, a leisure day's outing, or an extended overnight tour. To add to the enjoyment plan your outings with other WATER BIKE riders.

The catamaran configuration of the WATER BIKE makes it a very stable craft. It handles well in most rivers, lakes, sounds, bays and can maneuver easily through waves from moderate wind and boat wakes. Always wear your life jacket.

Like all watercraft, however, there are limits to the conditions in which the WATER BIKE can safely operate. The operator should use common sense in the use of the WATER BIKE. The WATER BIKE should not be used in the following conditions.

- The breaking waves, of higher than 3 ft.
- Rivers with strong current or white water.
- Waves from winds, which exceed 20 miles per hour.

All in all you'll find the WATER BIKE a fun, safe way to enjoy the water in the quiet of your own power.

TRANSPORTING THE WATER BIKE

The WATER BIKE can be disassembled in minutes without tools (consumer model only) for easy transport. It is also easy to carry since the heaviest component (hulls and frame assembly) weighs less than 20 lbs.

The hulls can be mounted on top of a car equipped with most standard all-purpose roof racks. Other components can be carried either on a rack or inside your vehicle. If the steering bar is removed the aft pontoons will fold in so it fits nicely without disassembling in the back of a full size pickup or van.

